

## High Productivity Cooking Electric Pressure Braising Pan, 125lt Hygienic Profile, Freestanding with CTS & Tap

ITEM # \_\_\_\_\_

MODEL # \_\_\_\_\_

NAME # \_\_\_\_\_

SIS # \_\_\_\_\_

AIA # \_\_\_\_\_

**586817 (PUEN12KCEM)**

Electric Pressure Braising Pan 125lt (h) with steam condensation function, core temperature sensor and mixing tap, GuideYou panel, freestanding

### Short Form Specification

**Item No.** \_\_\_\_\_

AISI 304 stainless steel construction. Pan in AISI 304 stainless steel; 18mm thick pan bottom (15mm mild steel and 3 mm AISI 316 stainless steel). Insulated and counterbalanced lid. Water mixing unit included. Unit to include food tap. The electric heating elements are mounted under the well. Safety thermostat protects the pan from overheating. A precise, electronic control of pan bottom temperature ensures fast reaction and exact adherence to preselected cooking temperatures between 50° and 250°C. The steam condensation function automatically nullifies the steam pressure after cooking is completed at the end of the cooking cycle. It can be used for poaching or steaming (with the lid open); simmering and boiling (with open or closed lid); pressure cooking of multiple produces possible thanks to the use of suspended GN 1/1 containers. TOUCH control panel. SOFT function. PRESSURE function. Possibility to store recipes in single or multiphase cooking process, with different temperature settings. Built in temperature sensors for precise control of cooking process. Core Temperature Sensor provides efficient temperature control. IPX6 water resistant. Configuration: Free-standing or Standing against a wall. Installation options (not included): floor mounted on 200mm high feet or a plinth which can be either steel or masonry construction.

### Main Features

- Multifunctional cooking appliance used for roasting, pot-roasting, braising, simmering, boiling, pressure cooking and steaming.
- Square inner kettle allows working with stacked Gastronorm containers, which facilitate loading and unloading operations.
- Thermoblock heating system for optimal temperature distribution and high temperature stability.
- Pan bottom with two individually adjustable heating zones, each with a temperature sensor.
- Large capacity food tap enables safe and effortless discharging of contents.
- Easy to clean cooking surface due to large-radius edges and corners.
- Temperature sensors provides efficient temperature control: the power is supplied as and when required to keep the set temperature value without exceeding it.
- Cooking with a working pressure of 0.45 bar reduces cooking times.
- Optimum heat distribution in the food provides best cooking results in terms of taste, colour and consistency and in terms of vitamin preserving.
- Discharge tap is very easy to disassemble and clean.
- Overnight cooking: saving electricity and time.
- Safety mechanism prevents lid from opening, even in case of voluntary attempt, when cooking under pressure.
- Safety valve on the lid avoids overpressure in the food compartment.
- IPX6 water resistant.
- "Pressure function": once the pressure lid is locked, the system automatically regulates itself.
- Built in temperature sensor to precisely control the cooking process.
- Core Temperature Sensor (CTS): multi-sensor food probe, 6 sensors, 0,5 °C accuracy, provides efficient temperature control. The power is supplied as and when required to keep the set temperature value without exceeding it and once reached, the food is ready to be served.
- No overshooting of cooking temperatures, fast reaction.
- USB connection to easily update the software, upload/download recipes and download HACCP data.
- Connectivity ready for real time access to connected appliances from remote and data monitoring (requires optional accessory -

**APPROVAL:** \_\_\_\_\_

contact the Company for more details).

## Construction

- Minimised presence of narrow gaps for easier cleaning of the sides to meet the highest hygiene standards.
- Multipurpose non-stick cooking surface in 18 mm thick compound: 3 mm shot-blasted 1.4404 (AISI 316L) stainless steel surface, seamlessly welded to the mild steel bottom.
- Double-lined insulated lid in 1.4301 (AISI 304) stainless steel mounted on the cross beam of the unit, counterbalanced by a hinge that remains open in all positions.
- External panelling and internal frame made of 1.4301 (AISI 304) stainless steel.
- 15 mm thick heating layer concealed below the entire pan bottom, to provide high thermal diffusion and heat storage properties.
- 2" diameter discharge tap for rapid emptying of the well.
- Pressure lid fitted with a proven fast-acting lock which is simple and safe in operation.
- Water mixing tap is available as optional accessory to make water filling and pan cleaning easier.
- Heatproof handle with non-slip surface.
- Front-mounted inclined led "TOUCH" control panel with recessed deep drawn casing, features self-explanatory display functions which guide operator throughout the cooking process: simultaneous display of actual and set temperature as well as set cooking time and remaining cooking time; real time clock; "SOFT" control for gentle heating up for delicate food; 9 power simmering levels from gentle to heavy boiling; timer for deferred start; error display for quick trouble-shooting.
- Possibility to store recipes in single or multiphase cooking process, with different temperature settings.
- "Boiling" or "Braising" mode functions.
- Can be prearranged for energy optimisation or external surveillance systems (optional).
- 98% recyclable by weight; packaging material free of toxic substances.
- Lateral surface of the vessel in DIN 1.4301/AISI 304.
- GuideYou Panel - activated by the user via settings - to easily follow the multiphase recipes, granting a proper and controlled cooking and a better appliance optimization. The system will provide maintenance reminders, in line with ESSENTIA program, helping the user to properly take care of the product, avoiding downtimes.
- Highly-visible and bright led TOUCH control panel features user-friendly icons and intuitive self-explanatory command options. Display visualizes:
  - Actual and set temperature
  - Set and remaining cooking time
  - Pre-heating phase (if activated)
  - GuideYou Panel (if activated)

- Deferred start
- Soft Function to reach the target temperature smoothly
- 9 Power Control levels from simmering to fierce boiling
- Pressure mode (in pressure models)
- Stirrer ON/OFF settings (in round boiling models)
- Error codes for quick trouble-shooting
- Maintenance reminders

## Sustainability



- High-quality thermal insulation of the pan saves energy and keeps operating ambient temperature low.

## Optional Accessories

- Strainer for dumplings for all tilting & stationary braising and pressure braising pans (except 80lt) and for all stationary rectangular and 100lt round boiling pans PNC 910053
- Scraper for dumpling strainer for boiling and braising pans PNC 910058
- Suspension frame GN1/1 for rectangular boiling and braising pans PNC 910191
- Base plate 1/1 GN for braising pans PNC 910201
- Perforated container with handles 1/1GN (height=100mm) for boiling and braising pans PNC 910211
- Perforated container with handles 1/1GN (height 150mm) for boiling and braising pans PNC 910212
- Small perforated shovel for braising pans (PFEN/PUEN) PNC 911577
- Small shovel for braising pans (PFEN/PUEN) PNC 911578
- Scraper with horizontal handle for braising pans (PFEN/PUEN) PNC 911579
- Perforated container with handles 1/1GN (height 200mm) for boiling and braising pans PNC 911673
- Power Socket, CEE16, built-in, 16A/400V, IP67, red-white - factory fitted PNC 912468
- Power Socket, CEE32, built-in, 32A/400V, IP67, red-white - factory fitted PNC 912469
- Power Socket, SCHUKO, built-in, 16A/230V, IP68, blue-white - factory fitted PNC 912470
- Power Socket, TYP23, built-in, 16A/230V, IP55, black - factory fitted PNC 912471
- Power Socket, TYP25, built-in, 16A/400V, IP55, black - factory fitted PNC 912472
- Power Socket, SCHUKO, built-in, 16A/230V, IP55, black - factory fitted PNC 912473
- Power Socket, CEE16, built-in, 16A/230V, IP67, blue-white - factory fitted PNC 912474

- |  |            |                          |  |            |                          |
|--|------------|--------------------------|--|------------|--------------------------|
| • Power Socket, TYP23, built-in, 16A/230V, IP54, blue - factory fitted   | PNC 912475 | <input type="checkbox"/> | • Scraper without handle for braising pans (PFEX/PUEX)   | PNC 913431 | <input type="checkbox"/> |
| • Power Socket, SCHUKO, built-in, 16A/230V, IP54, blue - factory fitted  | PNC 912476 | <input type="checkbox"/> | • Scraper with vertical handle for braising pans (PFEX/PUEX)   | PNC 913432 | <input type="checkbox"/> |
| • Power Socket, TYP25, built-in, 16A/400V, IP54, red-white - factory fitted  | PNC 912477 | <input type="checkbox"/> | • Kit endrail and side panels, flush-fitting, for back-to-back installation, left - factory fitted   | PNC 913483 | <input type="checkbox"/> |
| • Manometer for stationary pressure braising pans and rectangular pressure stationary boiling pans - factory fitted  | PNC 912492 | <input type="checkbox"/> | • Kit endrail and side panels, flush-fitting, for back-to-back installation, right - factory fitted  | PNC 913484 | <input type="checkbox"/> |
| • Connecting rail kit, 900mm   | PNC 912502 | <input type="checkbox"/> | • Kit endrail and side panel (12.5mm), for back-to-back installation, left - factory fitted  | PNC 913495 | <input type="checkbox"/> |
| • Stainless steel plinth for stationary units - freestanding - factory fitted  | PNC 912721 | <input type="checkbox"/> | • Kit endrail and side panel (12.5mm), for back-to-back installation, right - factory fitted   | PNC 913496 | <input type="checkbox"/> |
| • Set of 4 feet for stationary units (height 200mm) - factory fitted   | PNC 912732 | <input type="checkbox"/> | • Connectivity kit for ProThermetic Boiling and Braising Pans ECAP - factory fitted  | PNC 913577 | <input type="checkbox"/> |
| • Kit energy optimization and potential free contact - factory fitted  | PNC 912737 | <input type="checkbox"/> |  |            |                          |
| • Mainswitch 60A, 6mm <sup>2</sup> - factory fitted  | PNC 912740 | <input type="checkbox"/> | <b>Recommended Detergents</b>  |            |                          |
| • External touch control device for stationary units - factory fitted  | PNC 912783 | <input type="checkbox"/> | • C41 HI-TEMP RAPID DEGREASER. Suitable for cleaning plates and grills with high temperature surfaces (max 175°C). Pack of 6 l bottles (includes 1 spray bottle code 0S2331) | PNC 0S2292 | <input type="checkbox"/> |
| • Emergency stop button - factory fitted   | PNC 912784 | <input type="checkbox"/> |  |            |                          |
| • Automatic water filling (hot/cold) for round stationary boiling pans (width 1400-1700mm) - factory fitted  | PNC 912797 | <input type="checkbox"/> |  |            |                          |
| • Connecting rail kit: modular 90 (on the left) to ProThermetic tilting (on the right), ProThermetic stationary (on the left) to ProThermetic tilting (on the right) | PNC 912975 | <input type="checkbox"/> |  |            |                          |
| • Connecting rail kit: modular 80 (on the right) to ProThermetic tilting (on the left), ProThermetic stationary (on the right) to ProThermetic tilting (on the left) | PNC 912976 | <input type="checkbox"/> |  |            |                          |
| • Measuring rod and strainer for 125lt stationary braising pans  | PNC 913193 | <input type="checkbox"/> |  |            |                          |
| • Kit endrail and side panels, flush-fitting, left - factory fitted  | PNC 913394 | <input type="checkbox"/> |  |            |                          |
| • Kit endrail and side panels, flush-fitting, right - factory fitted   | PNC 913395 | <input type="checkbox"/> |  |            |                          |
| • Kit endrail and side panel (12.5mm), for installation thermaline 90 modular 700 mm high with ProThermetic stationary, left - factory fitted                        | PNC 913418 | <input type="checkbox"/> |  |            |                          |
| • Kit endrail and side panel (12.5mm), for installation thermaline 90 modular 700 mm high with ProThermetic stationary, right - factory fitted                       | PNC 913419 | <input type="checkbox"/> |  |            |                          |
| • Drain standpipe for boiling pans (PFEN & PUEN 08/12)   | PNC 913430 | <input type="checkbox"/> |  |            |                          |

Front

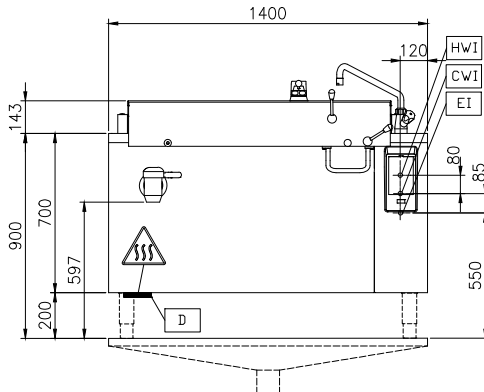

Side

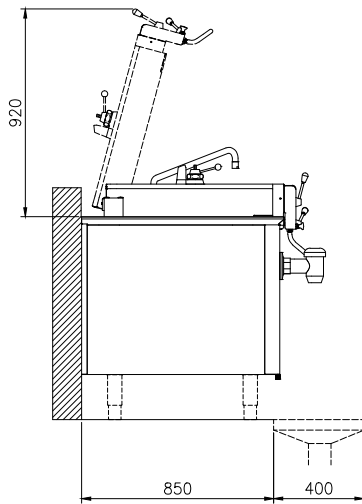

CWI = Cold Water inlet 1 (cleaning)  
 EI = Electrical inlet (power)  
 HWI = Hot water inlet

Top

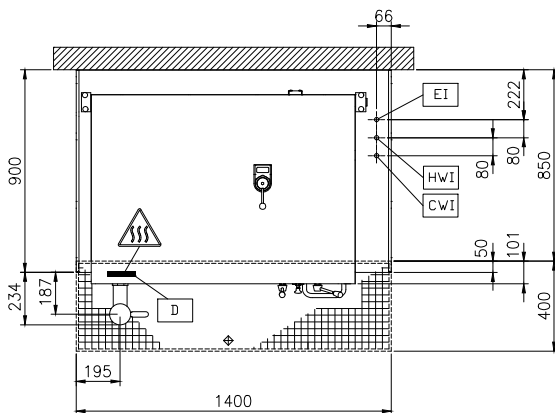

### Electric

Supply voltage:

586817 (PUEN12KCEM) 400 V/3N ph/50/60 Hz

Total Watts:

20.6 kW

### Installation:

FS on concrete base; FS on feet; On base; Standing against wall

Type of installation:

### Key Information:

Configuration: Rectangular; Fixed

Working Temperature MIN: 50 °C

Working Temperature MAX: 250 °C

Vessel (rectangle) width: 1080 mm

Vessel (rectangle) height: 260 mm

Vessel (rectangle) depth: 550 mm

External dimensions, Width: 1400 mm

External dimensions, Depth: 900 mm

External dimensions, Height: 700 mm

Net weight: 280 kg

Net vessel useful capacity: 125 lt

Double jacketed lid: ✓

Heating type: Direct